

Required Backshell

Part Number	Material
26POS-BS	Aluminum
SSB-26BS-PA66	Thermoplastic

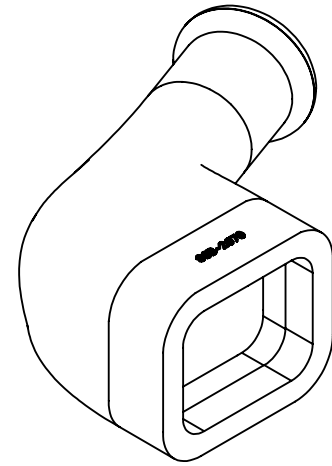
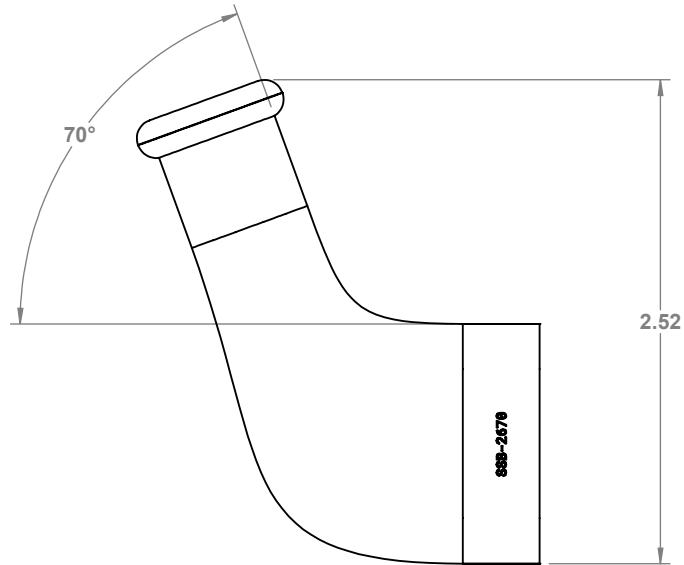

1

IF ADDITIONAL TAIL SEALING IS REQUIRED, A SHORT PIECE OF APPROPRIATELY SIZED ADHESIVE-LINED HEATSHRINK TUBING CAN BE USED. RECOMMENDED TUBING IS RAYCHEM TE ATUM-24/6-0-STK OR EQUIVALENT.

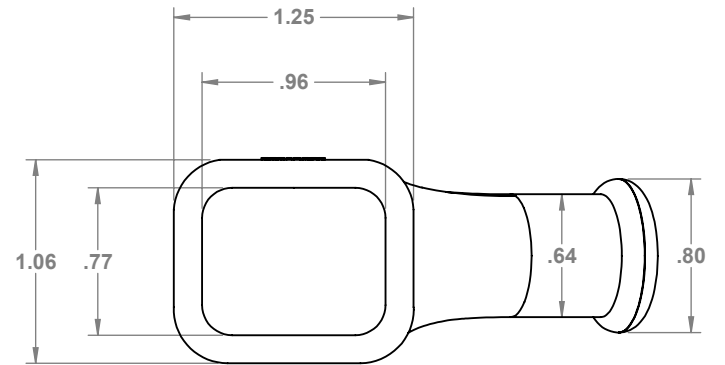
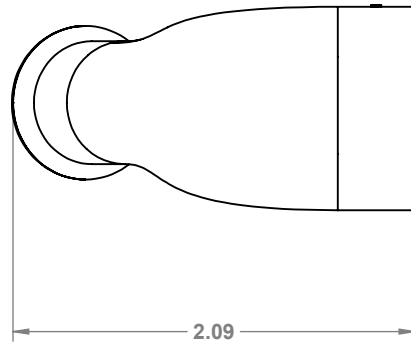
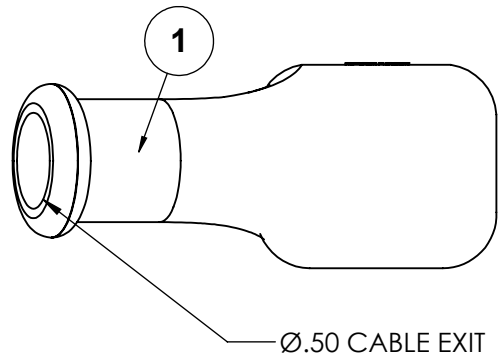

TITLE: **26 WAY SUPERSEAL 1.0 FLEXIBLE BOOT**

THIS PRINT, AND ALL INFORMATION THEREON, IS THE PROPERTY OF PROWIREUSA, LLC AND IS ON LOAN TO YOU ONLY ON THE CONDITION THAT WILL NOT COPY, REPRODUCE, TRANSMIT, OR SHOT THIS PRINT, OR ITS ESSENCE, IN WHOLE OR IN PART, TO A THIRD PARTY WITHOUT THE EXPRESS WRITTEN CONSENT OF PROWIREUSA, LLC.

MATERIAL: Flexible Rubber

FINISH: Matte Black

TOLERANCES UNLESS NOTED:
XXX ±.005 [1.127] X ±.1 [2.54]
.XX ±.02 [508] ANGLES ±1°

DRAWN BY: CJK DRAWN DATE: 11/18/22 SCALE: 1:1



ECO #	REV.	DESCRIPTION	DATE	BY
		REVISIONS		