

Required Backshell

Part Number	Material
34POS-BS	Aluminum
SSB-34BS-PA66	Thermoplastic

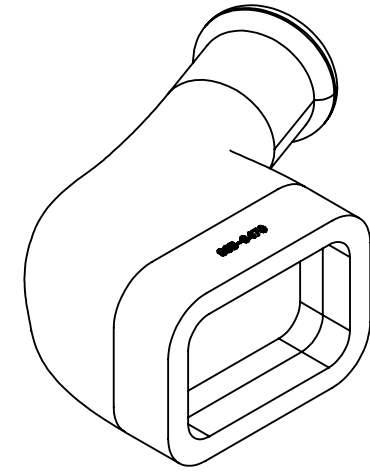
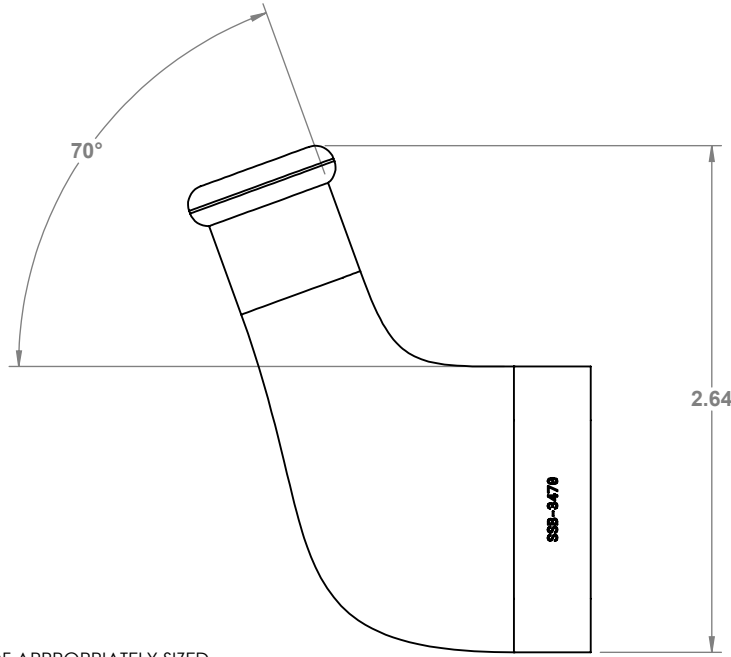

1

IF ADDITIONAL TAIL SEALING IS REQUIRED, A SHORT PIECE OF APPROPRIATELY SIZED ADHESIVE-LINED HEATSHRINK TUBING CAN BE USED. RECOMMENDED TUBING IS RAYCHEM TE ATUM-24/6-0-STK OR EQUIVALENT.

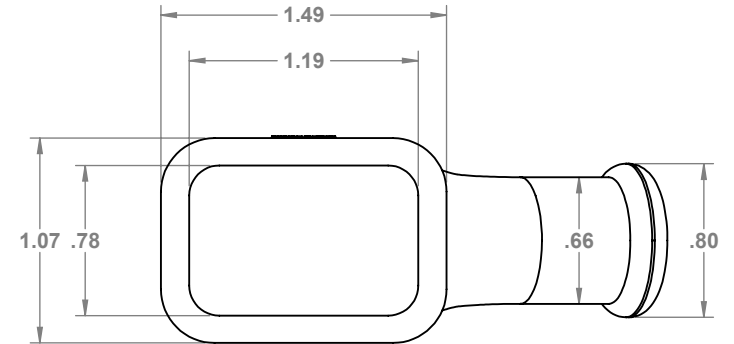
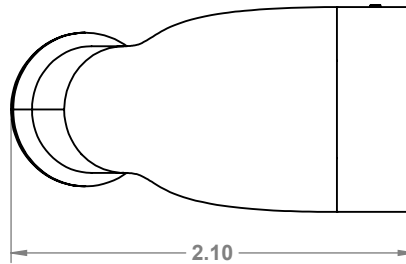
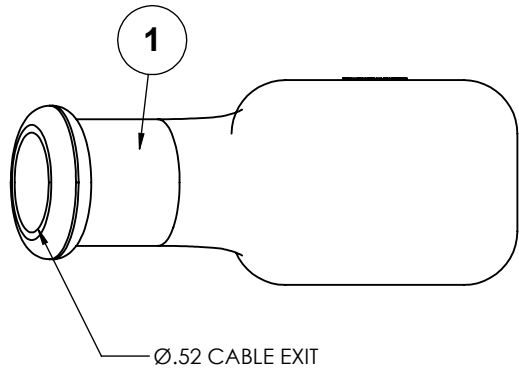

TITLE: **34 WAY SUPERSEAL 1.0 FLEXIBLE BOOT 70°**

THIS PRINT, AND ALL INFORMATION THEREON, IS THE PROPERTY OF PROWIREUSA, LLC AND IS ON LOAN TO YOU ONLY ON THE CONDITION THAT WILL NOT COPY, REPRODUCE, TRANSMIT, OR SHOT THIS PRINT, OR ITS ESSENCE, IN WHOLE OR IN PART, TO A THIRD PARTY WITHOUT THE EXPRESS WRITTEN CONSENT OF PROWIREUSA, LLC.

MATERIAL: Flexible Rubber
Operating Temperature -20°C - 120°C

FINISH: Matte Black
TOLERANCES UNLESS NOTED:
XXX ±.005 [1.27] X ±.1 [2.54]
XX ±.02 [508] ANGLES ±1°

DRAWN BY: CJK DRAWN DATE: 11/18/22 SCALE: 1:1



ECO #	REV.	DESCRIPTION	DATE	BY
		REVISIONS		