

2

1

B

B

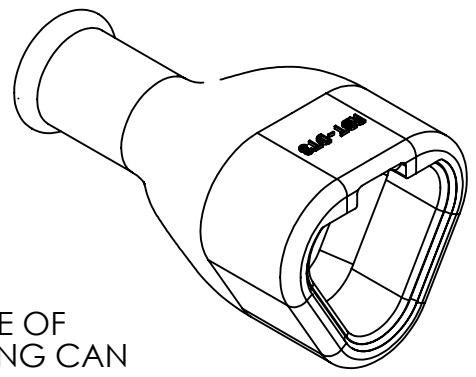
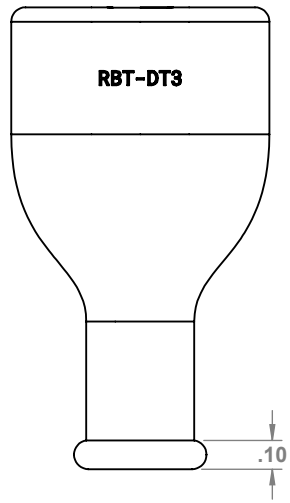

1

IF ADDITIONAL TAIL SEALING IS REQUIRED, A SHORT PIECE OF APPROPRIATELY SIZED ADHESIVE-LINED HEATSHRINK TUBING CAN BE USED.

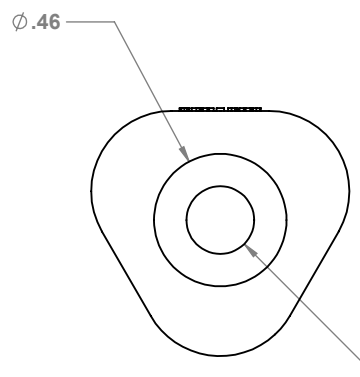

1

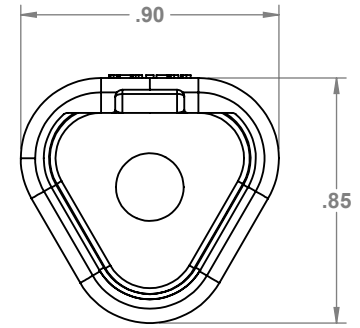
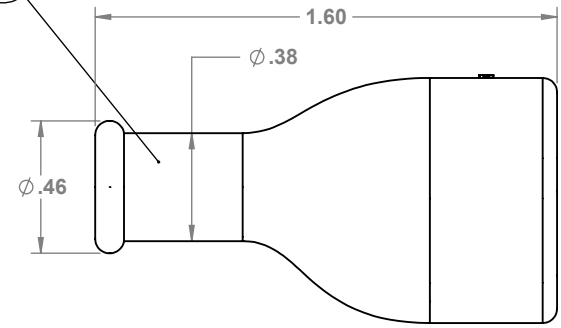

A

A

NOTES:
 TO BE USED WITH 3 WAY DEUTSCH DT SERIES HOUSINGS THAT USE THE INEGRATED SHRINK BOOT ADAPTER MODIFICATION.
 MOD CODES :
 • E008
 • CE13
 • CE04
 • EP11
 PLEASE REFER TO THE CONNECTOR MFG DATASHEETS FOR THE FILL LIST OF MOD CODES

PROPRIETARY AND CONFIDENTIAL
 THE INFORMATION CONTAINED IN THIS DRAWING IS THE SOLE PROPERTY OF PROWIREUSA, LLC. ANY REPRODUCTION IN PART OR AS A WHOLE WITHOUT THE WRITTEN PERMISSION OF PROWIREUSA, LLC IS PROHIBITED.
 COMMENTS:
 • INTENDED FOR GENERAL AUTOMOIVE AND INDUSTRIAL APPLICATIONS. RESITS COMMON AUTOMOTIVE FLUIDS
 TEMP: -40 °C-125°C
 APPLICATION AUTOMOTIVE / INDUSTRIAL

UNLESS OTHERWISE SPECIFIED:
 DIMENSIONS ARE IN INCHES
 TOLERANCES:
 FRACTIONAL ±
 ANGULAR: MACH ± BEND ±
 TWO PLACE DECIMAL ±
 THREE PLACE DECIMAL ±
 INTERPRET GEOMETRIC TOLERANCING PER:

	NAME	DATE
DRAWN	CJK	8/28/23
CHECKED	JD	8/28/23
MATERIAL:	FLEXIBLE RUBBER	
FINISH:	MATTE BLACK	
DO NOT SCALE DRAWING		

TITLE:		
DEUTSCH DT SERIES 3 WAY RUBBER BOOT		
SIZE	DWG. NO.	REV
A	RBT-DT3	0
SCALE: 1.5:1	WEIGHT: .00939 LBS	SHEET 1 OF 1



2

1