

2

1

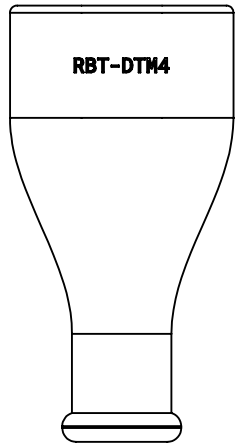

1

IF ADDITIONAL TAIL SEALING IS REQUIRED, A SHORT PIECE OF APPROPRIATELY SIZED ADHESIVE-LINED HEATSHRINK TUBING CAN BE USED.

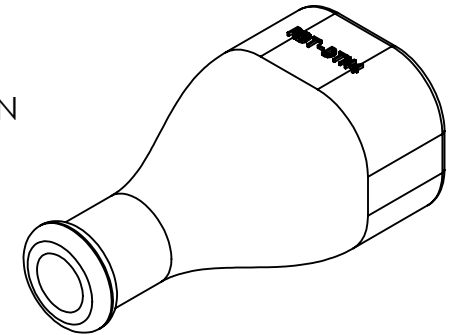

B

B

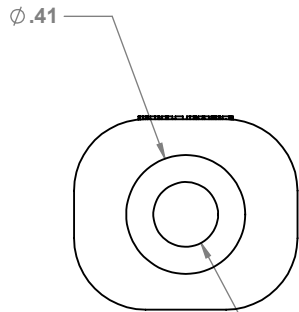

Ø.23 CABLE EXIT

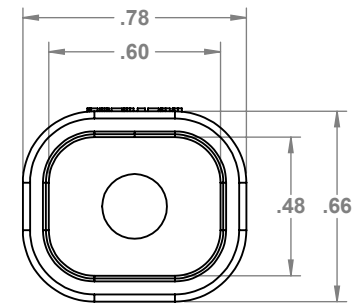
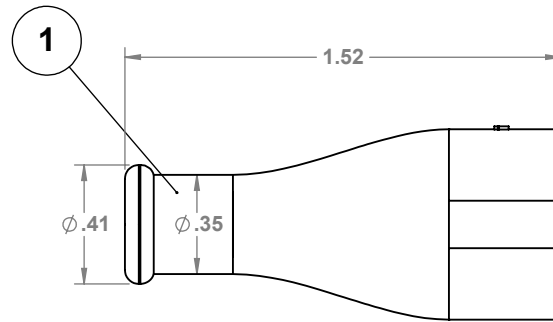

A

A

NOTES:

TO BE USED WITH 4 WAY DTM SERIES HOUSINGS THAT USE THE INTEGRATED SHRINK BOOT ADAPTER MODIFICATION.

MOD CODES :

- E007
- EE03

PLEASE REFER TO THE CONNECTOR MFG DATASHEETS FOR THE FULL LIST OF MOD CODES

PROPRIETARY AND CONFIDENTIAL

THE INFORMATION CONTAINED IN THIS DRAWING IS THE SOLE PROPERTY OF PROWIREUSA, LLC. ANY REPRODUCTION IN PART OR AS A WHOLE WITHOUT THE WRITTEN PERMISSION OF PROWIREUSA, LLC IS PROHIBITED.

COMMENTS:

- INTENDED FOR GENERAL AUTOMOTIVE AND INDUSTRIAL APPLICATIONS. RESISTS COMMON AUTOMOTIVE FLUIDS

TEMP:

-40 °C-125°C

APPLICATION: AUTOMOTIVE / INDUSTRIAL

UNLESS OTHERWISE SPECIFIED:

DIMENSIONS ARE IN INCHES
TOLERANCES:
FRACTIONAL ±
ANGULAR: MACH ± BEND ±
TWO PLACE DECIMAL ±
THREE PLACE DECIMAL ±

INTERPRET GEOMETRIC TOLERANCING PER:

	NAME	DATE
DRAWN	CJK	8/31/23
CHECKED	JD	8/28/23
MATERIAL	FLEXIBLE RUBBER	
FINISH	MATTE BLACK	

DO NOT SCALE DRAWING



TITLE:

**DEUTSCH DTM SERIES
4 WAY RUBBER BOOT**

SIZE	DWG. NO.	REV
A	DTM4-BT	0
SCALE: 1.5:1	WEIGHT: .00815 LBS	SHEET 1 OF 1

2

1