

LTR.	REVISIONS	DATE	INT.

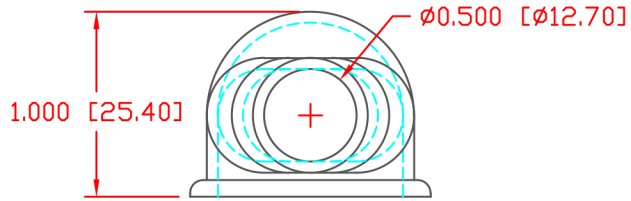

SEAL DETAILS  
WIRE GAGES: 2 - 2/0

SECTION A-A  
TYP. WALL THICKNESS = .060" [1.5]

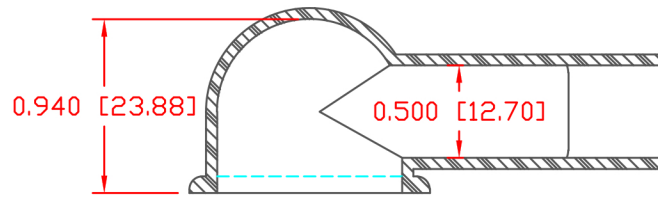
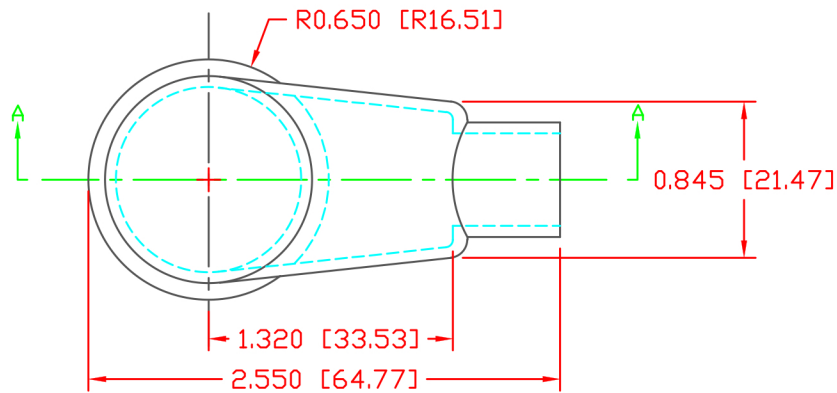

SCALE FACTOR : NONE  
ALL DIMENSIONS GIVEN AS: in [mm]  
TOLERANCES UNLESS OTHERWISE SPECIFIED :  
MOLDED PARTS: ±.030" [±0.8mm]  
ALL ANGLES ARE ± 1 DEGREE

MATERIAL:	PVC
VENDOR PART NO:	9812-65-BLACK
SHORE DUROMETER:	"A" 10 SEC. 65
SPECIFIC GRAVITY:	1.34
ULT. ELONGATION %:	400
MELTING TEMP:	315-335 F [157-168 C]
BRITTLE TEMP:	-54 F [-48 C]
TENSILE STRENGTH PSI:	1550 PSI
DIELECTRIC STRENGTH, V./mil:	453
U.L. RATING:	V2

DO NOT SCALE



REF:	DATE:	DRN BY:	BRH	WEIGHT:
CUSTOMER DIMS	03-26-98	CHK'D BY:	BRH	.019 LBS [8.48 g]
TITLE:		EYELET TERMINAL INSULATOR		
MATERIAL:		PVC		PART NO. <b>670135</b>
COLOR:	BLACK	DRG CLASS		