

LTR.	REVISIONS	DATE	INT.
△	ADDED REFERENCE DIMENSION	02-25-16	RAS

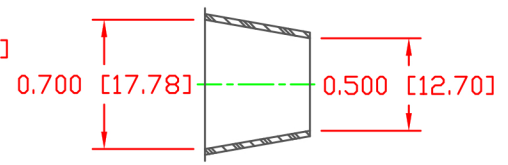

SECTION A-A
 TYP. WALL THICKNESS = .080" [2.0]
 SEAL NO. 3 SHOWN

SEAL THICKNESS = .030" [.8]
 NO. 3
 Cable Gages
 2 - 2/0

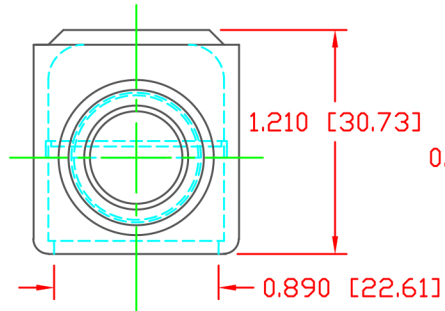
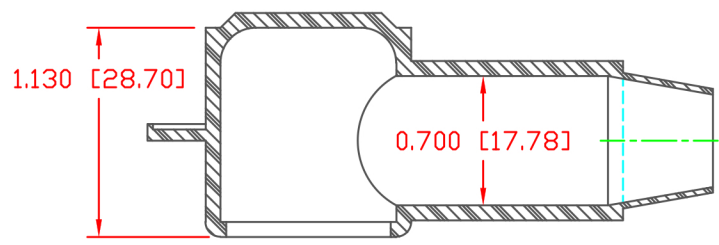
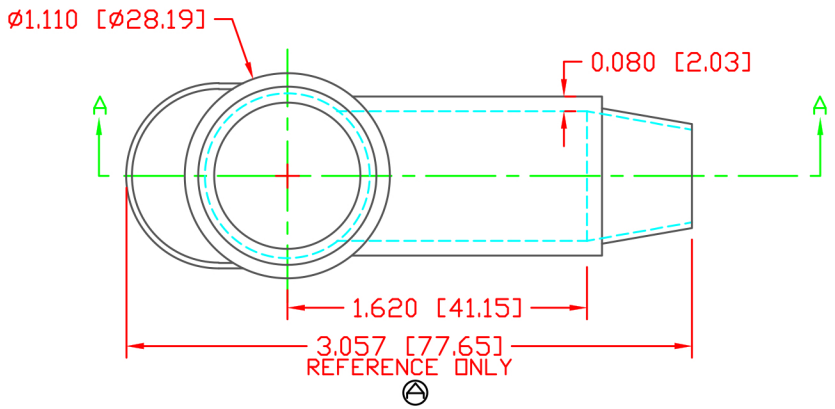

SCALE FACTOR : NONE
 ALL DIMENSIONS GIVEN AS: In [mm]
 TOLERANCES UNLESS OTHERWISE SPECIFIED :
 MOLDED PARTS: ±.030" [±0.8mm]
 ALL ANGLES ARE ± 1 DEGREE

MATERIAL:	PVC
VENDOR PART NO:	9812-65-BLACK
SHORE DUROMETER:	"A" 10 SEC. 65
SPECIFIC GRAVITY:	1.34
ULT. ELONGATION %:	400
MELTING TEMP:	315-335 F [157-168 C]
BRITTLE TEMP:	-54 F [-48 C]
Tensile Strength PSI:	1550 PSI
Dielectric Strength, v./mil	453
U.L. Rating:	V2

DO NOT SCALE



REF:	DATE:	DRN BY: JC	WEIGHT:
CUSTOMER DIMS	03-24-98	CHK'D BY: JC	.030 LBS [13.7 g]
TITLE: TERMINAL INSULATOR CAP			
MATERIAL: PVC		PART NO.	
COLOR: BLACK		670141	
DRG CLASS: REV A			